

EDD – 100

BASIC LOGIC

GENERAL DESCRIPTION

The purpose of this **EDD100001** module is the study of the fundamental electronic circuits of the basic logic.

List of logic functions :

- ◆ 2 Resistors, 3 Diodes, 1 Transistor (Réalisation of AND, OR, NOR, NAND in RTL & DTL technologies)
- ◆ 6 NOT ◆ 8 AND 2 inputs ◆ 8 NAND 2 inputs ◆ 3 NAND 3 inputs ◆ 8 OR 2 inputs ◆ 8 NOR 2 inputs ◆ 3 NOR 3 inputs ◆ 4 XOR 2 inputs

Flip-Flops :

- ◆ 2 RS ◆ 2 RSH ◆ 2 D ◆ 4 JK

Services Functions :

- ◆ 1 Potentiometer
- ◆ 1 Bounce-free pushbutton
- ◆ 1 Pushbutton to be wired
- ◆ 1 Fixed clock : 1 KHz
- ◆ 1 Adjustable clock : 0 to 2 KHz
- ◆ 8 Switches for programming 0 or 1 levels
- ◆ 8 Logic state LED displays
- ◆ 2 adaptators (BNC/ 2 mm sockets)
- ◆ External plug-in power supply (7-12 V AC or DC)

FIELDS OF APPLICATION

Fundamental and Further Education :

Efficient and professional training on the basic logic functions used in the electronic industry :

- ◆ Vocational training
- ◆ Secondary and Higher Technical Education
- ◆ Universities and Engineers Schools

Securities :

- ◆ Electronic protection against short-circuits and over-voltages
- ◆ Security fuses
- ◆ Easy maintenance : all active components on sockets for easy and fast replacing
- ◆ Option : Fixing of the active components (soldered jump)

PARTICULARITIES

The front-face corresponds to the technical manuals and data books in such a way to introduce very rapidly the student to the professional reality. You have an exact wiring correspondance with the « DATA-SHEETS ».

Example of a 7400 NAND function :

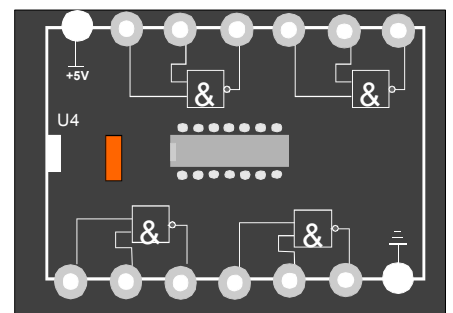

Packaging

Weight : 3 Kg
Dimensions : 284 x 336 x 42 mm

EDD100001 Basic Logic Module : Technical characteristics :

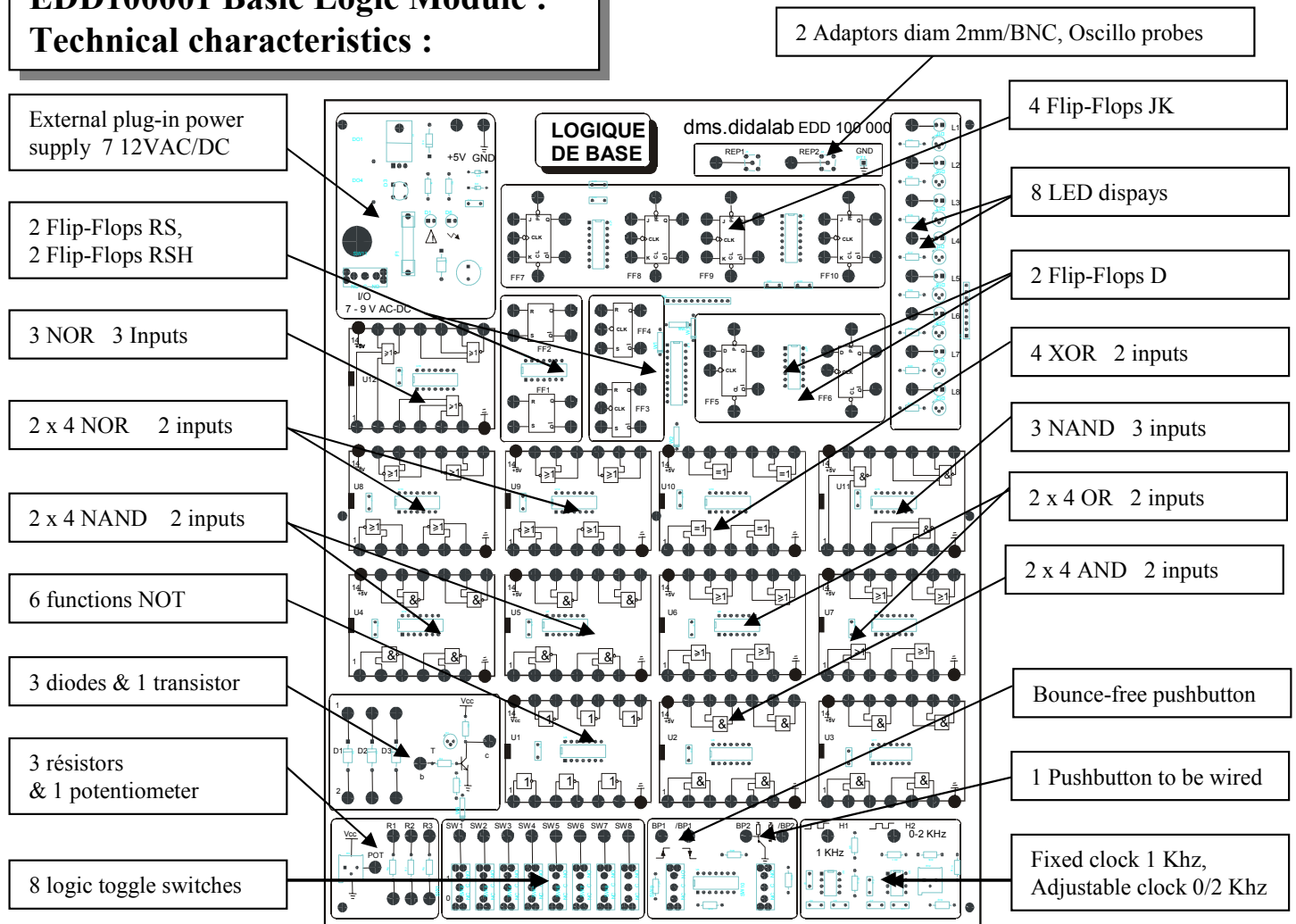

Training manual : EDD100041 Teacher Practical Works

Basic logic :

Study of the following functions : OR & AND (diodes), NOR & NAND (diodes & transistors)

Study of the commutation levels in the TTL technology

Study and verification of the Truth Table : NOT, AND, OR, NAND, NOR, EXCLUSIVE OR

Réalisation of : 2 bits equality comparator in combinatory logic

4 bits complete equality comparator in combinatory logic

1 & 2 bits binary multiplier in combinatory logic

Sequential logic :

Study of :

- RSH Flip-Flop
- D Flip-Flop
- JK Flip-Flop

Combinatory logic réalisation of :

- RS Flip-Flop with NOR gates
- Bounce-free with NOR gates
- RS Flip-Flop with NAND gates
- Bounce-free with NAND gates
- D, RSH & JK Flip-Flops.

Flip-Flops applications :

Réalisation of : 2 bits asynchronous binary counter with D Flip-Flops

4 bits asynchronous binary counter with JK Flip-Flops

4 bits synchronous binary counter with JK Flip-Flops and combinatory logic

4 bits synchronous BCD counter with JK Flip-Flops and combinatory logic

4 bits synchronous binary modulo N counter with JK Flip-Flops and combinatory logic

4 bits programmable counter.

Document non contractuel