

**ESD 100 SI**  
**ESD 100 SE**

## Study of Automatic control

ESD 100 SI / ESD100 SE is a modular board designed to ensure a very progressive training in the field of automation. Two versions for this bench:

- Siemens® PLC and HMI
- Schneider Electric® PLC and HMI

*Compatible avec toutes nos parties opératives d'automatisme: (Monte charges, ascenseur, feux de carrefour, cellule électropneumatique)*

## Pedagogical purposes

- Study of a developed wiring diagram in automation
- Study and implementation of a PLC network
- Study of PLC programming
- Study of HMI programming

## Targeted trainings

- Vocational Training
- Technical high schools
- Polytechnics
- Technical Bachelor
- Engineer schools

## ESD 106 000 : Electric power supply module

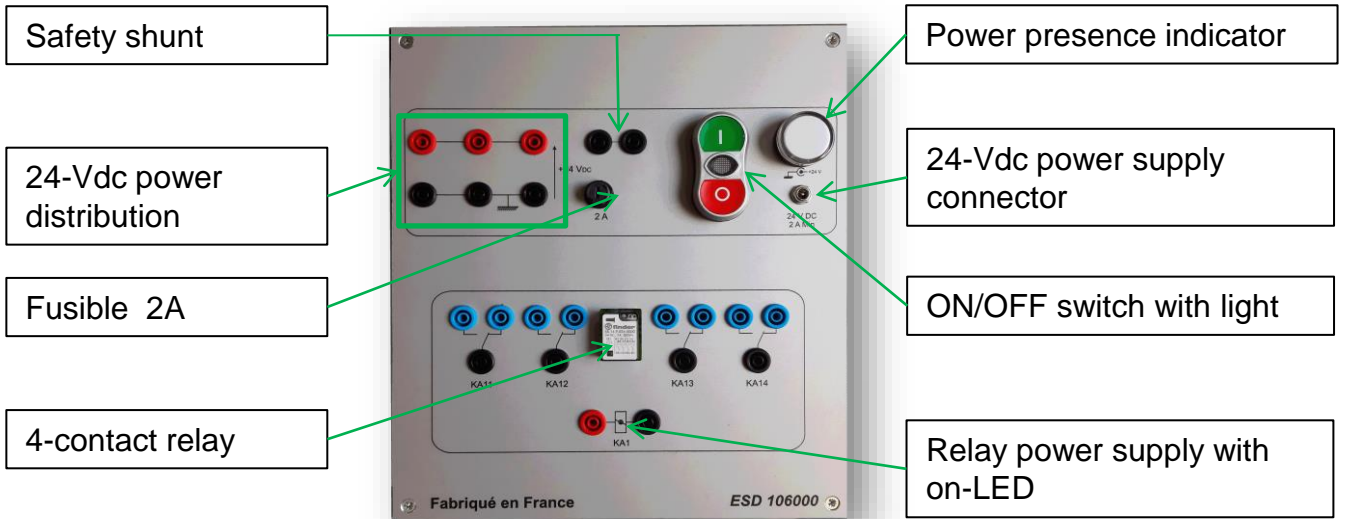

## ESD 105 000 : Electric HMI module



## ESD 108 000 : KTP 700 HMI module

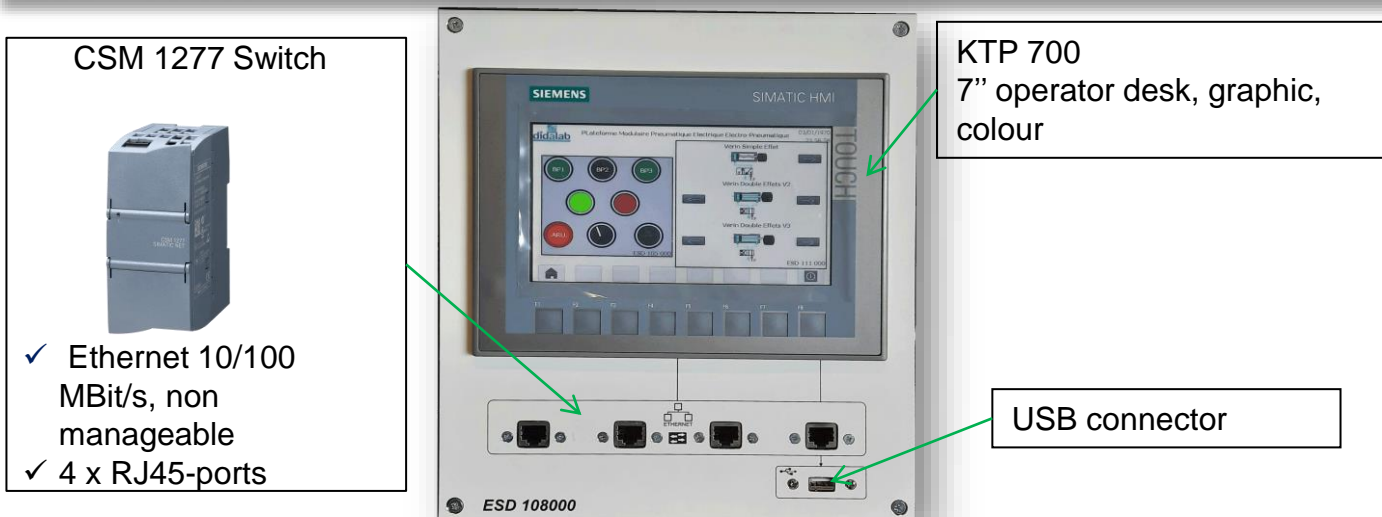

# ESD 107 000 : S7-1200 PLC module with Tia Portal software

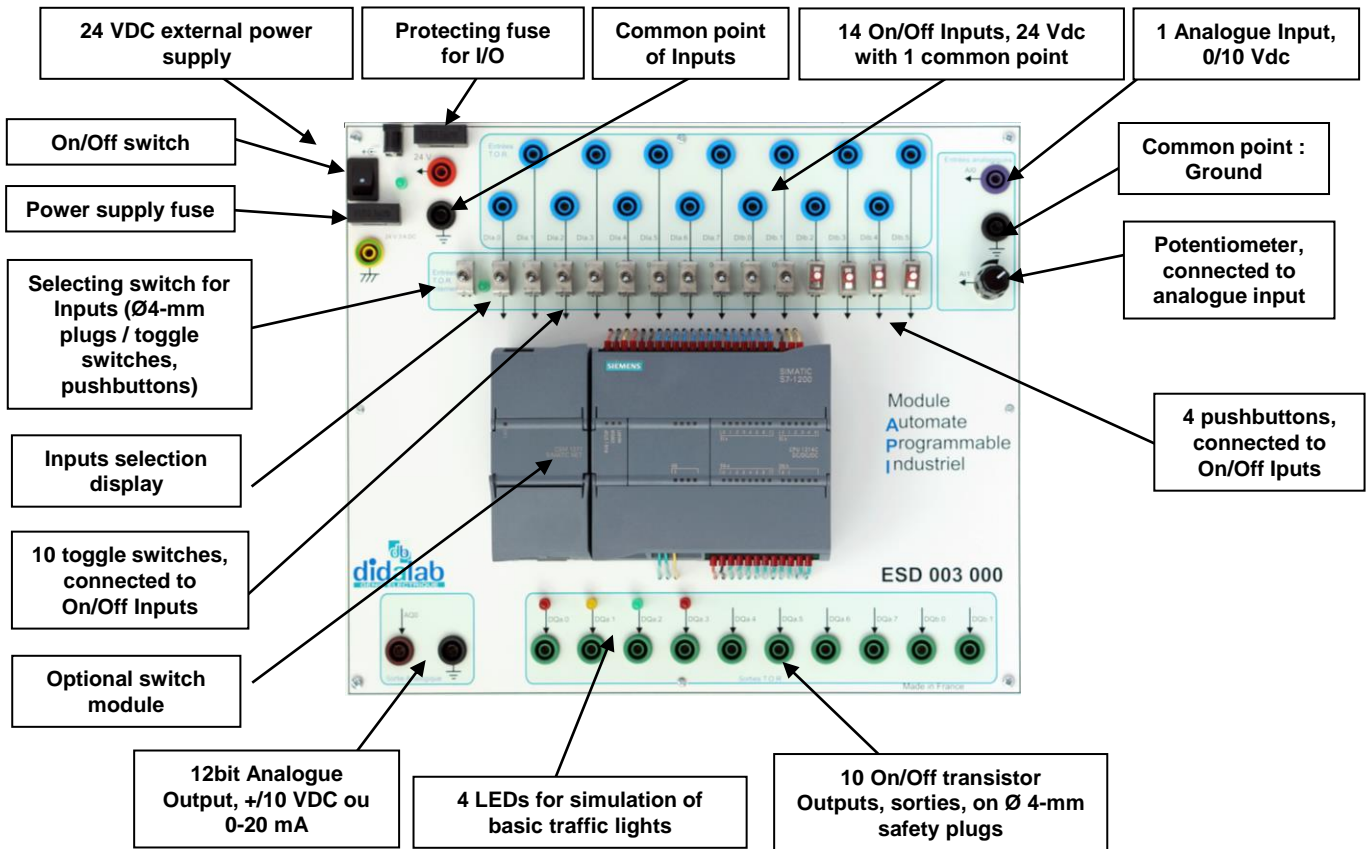

## Softwares



**Tia Portal** : Work environment for the integrated development of SIMATIC STEP 7 applications



**Automgen** : programming software for Grapcet, Gemma, Ladder, logigram, ...

## Alternative

### Version with Schneider PLC and HMI

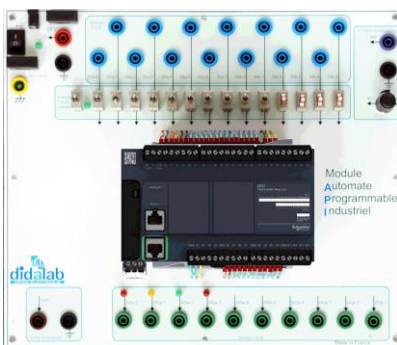

ESD113000 : M221 PLC



ESD114000 : Magelis HMI

**ESD 10x 000** : for another PLC model: please ask

## Standard configuration:

**SIEMENS**

### ESD 100 SI : PLC modular bench (Siemens)

Reference	Description	Qty
ESD100400	Structure profilé aluminium 4 emplacements pour modules, électriques, Automate Structure made of aluminium profile, with 4 locations for electrical and PLC modules.	1
	1 USB flash drive with the technical guide, the pedagogical manual with experiments	1
ESD106000	Electrical power supply module	1
ESD107000	PLC module	1
	S7-1200 PLC, supplied with TIA Portal software	
	- 14 On/Off Inputs, 24 VDC, 10 outputs with state visualization,	
	- 1 analogue Input, 0/10 V ; 1 analogue output, +/-10V, 12 bits,	
	- 1 simulator with 8 miniswitchs	
	Put on a pedagogical module with Ø 4-mm security	
ESD003100	Automgen software extension	1
ESD108000	KTP 700 HMI module with 4 RJ45-ports and 1 USB connector	1
ESD105000	Electric HMI interface (1 Emergency stop button, 1 green light, 1 red light, 2 2-position switches, 2 green push-buttons, 1 black push-button)	1
PEM080030	Set of 10 patching cords, 1 m, black, Ø4-mm safety sockets, stackable	1
PEM080031	Set of 10 patching cords, 1 m, red, Ø4-mm safety sockets, stackable	1
PEM080032	Set of 10 patching cords, 1 m, blue, Ø4-mm safety sockets, stackable	1

**Schneider**  
Electric

### ESD 100 SE : PLC modular bench (Schneider Electric)

Reference	Description	Qty
ESD100400	Structure made of aluminium profile, with 4 locations for electrical and PLC modules.	1
	1 USB flash drive with the technical guide, the pedagogical manual with experiments	1
ESD106000	Electrical power supply module	1
ESD113000	PLC module	1
	M221 PLC, supplied with SoMachine software:	
	- 14 On/Off Inputs, 24 VDC, 10 outputs with state visualization,	
	- 2 analogue inputs, 0/10 V ; 1 analogue output, 0/10V,	
	- 1 simulator with 8 miniswitchs	
	Put on a pedagogical module with Ø 4-mm security	
ESD114000	Magelis HMI module	1
ESD105000	Electric HMI interface (1 Emergency stop button, 1 green light, 1 red light, 2 2-position switches, 2 green push-buttons, 1 black push-button)	1
PEM080030	Set of 10 patching cords, 1 m, black, Ø4-mm safety sockets, stackable	1
PEM080031	Set of 10 patching cords, 1 m, red, Ø4-mm safety sockets, stackable	1
PEM080032	Set of 10 patching cords, 1 m, blue, Ø4-mm safety sockets, stackable	1

Space requirement: 630x700x300 mm