

8/16 BITS 68HC12 MICROCONTROLLER BASED SYSTEM EID – 110

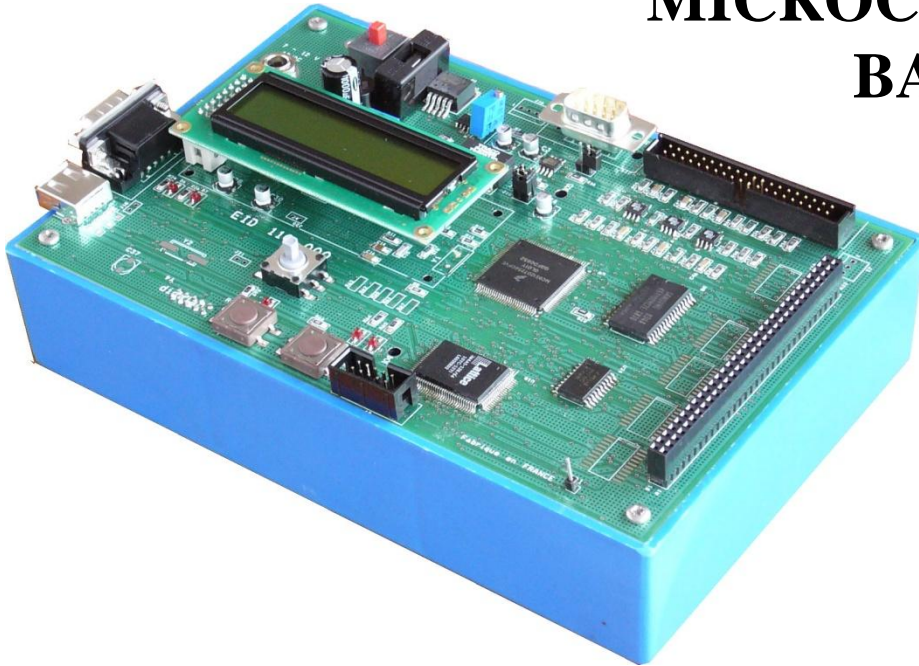

CONFIGURATIONS :

The **EID 110 B** System (including the EID 110 000 board & accessories) enables the study of microprocessors & microcontrollers from the 68HC12 group (kernel of 6800). It is a member of the complete family of Training Aids to the understanding of digital techniques :

- ◆ The **EDD 100** serie, enabling the introduction to the basic wiring logic (combinatory, flip-flops, counters, ALU),
- ◆ The **EDD 200** serie, dealing with the programmable logic (EPLD circuits linked to the VHDL language),
- ◆ The **EID 100** serie, microprocessors & microcontrollers from the 8 bits Motorola & Intel components family.
- ◆ The **EID 200** serie, microprocessors & microcontrollers from the 16 bits & 32 bits Motorola et Intel comonents family.
- ◆ The **EID 300** serie, DSP microprocessors.
- ◆ One complete range of actuated parts enables to put the student in industrial development context, (Inputs/Outputs simulator, Traffic lights, Speed & Position servo system, Air flow & Temperature Process control, Multiplexed Vehicle enabling the study of CAN BUS, Ethernet board).

CHARACTERISTICS :

The **EID 110 000** board enables the study of the architecture of a 8/16 bits microprocessor-based microsystem, 68HC12 microcontroller (fully compatible to 68HC11) 16 MHz clock, 256 KBytes of EEPROM flash ,
4 Kbytes of EEPROM & 12 + 128 KBytes of 8 bits RAM, USB Port, RS232, ASCII 16 characters LCD Display, 5 keys Keypad/joystick, PC104 bus giving access to many available Inputs/Outputs boards, 24 bits //port, 6 analogue I & 4 O on HE10 40pts, SPI port & I2C.

Basic version :

- ◆ One PC editor,
- ◆ One Cross assembler,
- ◆ One debugger monitor,

Hardware options :

- ◆ Industrial extension boards (PC104 size): Ethernet, CAN Bus interface, Inputs/Outputs (ON/OFF, optoelectronics, relay...),
- ◆ Inputs/Outputs modules remoted to CAN network (8 ON/OFF I/O, 4 Power outputs, Servo Motor),
- ◆ One C Cross compiler.

AREAS OF

APPLICATION :

- ◆ Technical Colleges,
- ◆ Vocational Schools,
- ◆ University.

SAFETY DEVICES:

- ◆ Protection by fuse & transil of the board Power Supply,
- ◆ Electronic protection against short-circuits & overvoltage on the parallel port ,
- ◆ Protection of PC 104 bus Inputs/Outputs by Buffers,

EID 110 000 8/16 bits microcontroller processor board 68hc12 Motorola (68HC11 code compatible)

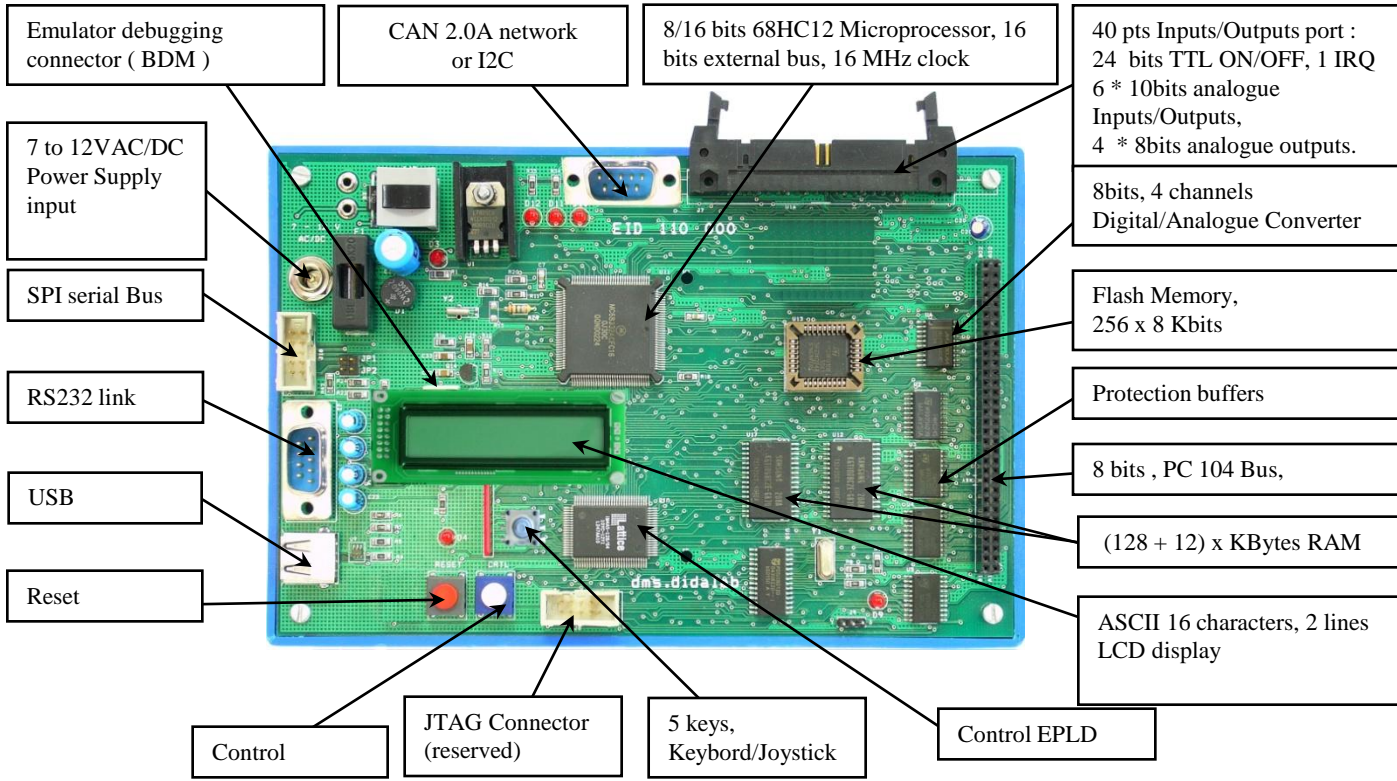

The board is provided in basic version, with a Software pack operating on PC. (Windows 95 to Windows Vista) including :

- ◆ page mode Editor under Windows with low level function bibliary
- ◆ Cross assembler, Warrior Code ** compiler linker, evaluation version, clamped to 32 KB of executable code generating object files at Motorola S record format
- ◆ Setting up debugger, including functions :
 - registers modification & display,
 - CPU operation in step-by-step mode, stop points plotting,
- ◆ Technical Handbook with electronic layouts Ref : **EID 110 010**.

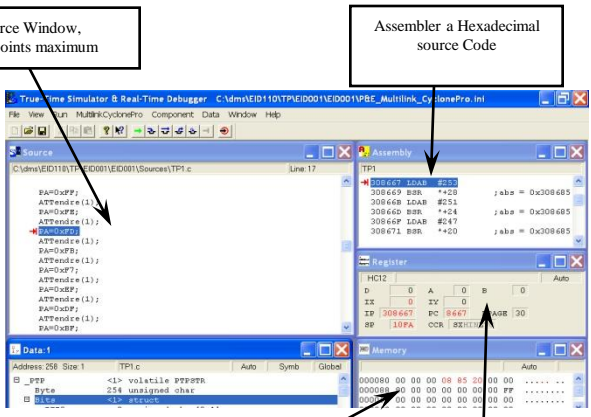

EID 110 100 : C Compiler development environment,

General features :

- C Compiler, GNU with StDIO libraries (Standard Data Input Output), String (characters chain control),
- Control Data Structures of EID 110 000 Board (68hc12 registers, Analogue/Digital Converters, PC104 BUS,...) & different actuated parts (Inputs/Outputs simulator, Traffic Lights, CAN network & Ethernet Boards...),
- Low level functions library (interrupt control, USB port & RS232...),
- Linker specifically configured for EID 110 000 Board.

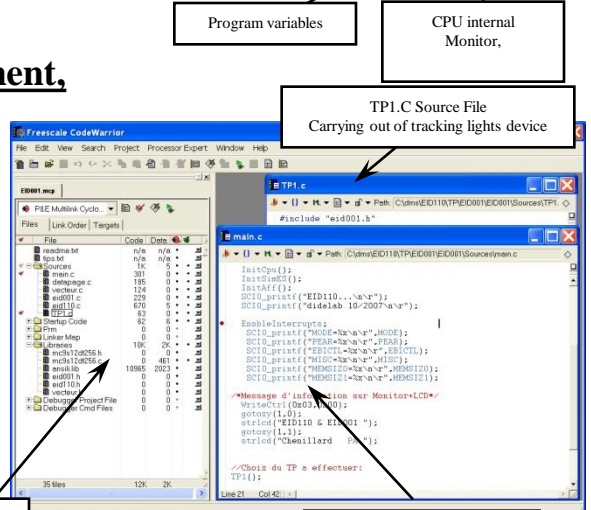

Practical Work Manual

EID 110 040, discovering the EID 110 000 Board, storage writing, selection of memory area...(62 pages, 2x5 Experiments

** Warrior Code, registered mark

EID 001 000 Inputs Outputs Simulator

It is connected to the 40 pins Inputs/Outputs port of the EID 110 000 Board and enables the simulation of some operational parts:

- 8 display LED's on the port output, 8 Micro switches on the port input,
- 1 bounce-free pushbutton (interrupt input),
- 1 Potentiometer on analog input, 1 LED on analog output.

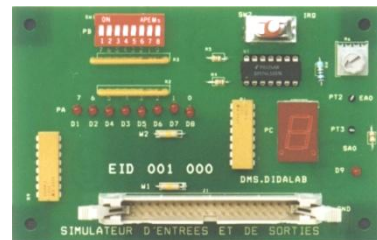

Manuel de Travaux Pratiques

EID 111 140 programmation et écriture lecture d'un port //, A/N, gestion d'interruptions... (46 pages)

Standard configuration :

EID 110 B : Basic Pack " 68HC12 8/16 bits MICROPROCESSOR/MICROCONTROLLER SYSTEM & C LANGUAGE " including :

| Reference | Designation | Qty |
|-------------|--|-----|
| EID 110 000 | 68HC12 microcontroller Study Board, with editor, cross assembler / linker, debugger, technical manual, | 1 |
| EID 110 100 | Development environment, GNU C compiler, GDB single station applied to EID11000, | 1 |
| EID 001 000 | Input/Output Simulator, with 40 pointslayer, | 1 |
| EGD 000 003 | DB9/DB9 F/F X modem serial lead, | 1 |
| EGD 000 021 | USB/RS232 adapatator | 1 |
| EGD 000 001 | 8 VAC, 2 Amp, Power Supply, | 1 |
| EID 110 040 | Manuel of Experiments for EID110000 Board, source files on CDROM | 1 |
| EID 111 040 | Manuel of Experiments for EID110000 Board with applications on EID 001000 I/O board, source files on CDROM | 1 |

Packing :

EID 110 B : Dimensions 35 x 30 x 30 cm, weight 5 kg

Document non contractuel

Modification du : 04/06/08